

Approval body for construction products
and types of construction

Bautechnisches Prüfamt

An institution established by the Federal and
Laender Governments



European Technical Assessment

ETA-02/0031
of 28 January 2021

English translation prepared by DIBt - Original version in German language

General Part

Technical Assessment Body issuing the
European Technical Assessment:

Deutsches Institut für Bautechnik

Trade name of the construction product

Würth High-Performance Anchor W-HAZ

Product family
to which the construction product belongs

Mechanical fastener for use in concrete

Manufacturer

Adolf Würth GmbH & Co. KG
Reinhold-Würth-Straße 12-17
74653 Künzelsau
DEUTSCHLAND

Manufacturing plant

Herstellwerk W1,
Deutschland

This European Technical Assessment
contains

22 pages including 3 annexes which form an integral part
of this assessment

This European Technical Assessment is
issued in accordance with Regulation (EU)
No 305/2011, on the basis of

EAD 330232-00-0601, Edition 10/2016

This version replaces

ETA-02/0031 issued on 1 October 2018

The European Technical Assessment is issued by the Technical Assessment Body in its official language. Translations of this European Technical Assessment in other languages shall fully correspond to the original issued document and shall be identified as such.

Communication of this European Technical Assessment, including transmission by electronic means, shall be in full. However, partial reproduction may only be made with the written consent of the issuing Technical Assessment Body. Any partial reproduction shall be identified as such.

This European Technical Assessment may be withdrawn by the issuing Technical Assessment Body, in particular pursuant to information by the Commission in accordance with Article 25(3) of Regulation (EU) No 305/2011.

Specific Part

1 Technical description of the product

The Würth High-Performance Anchor W-HAZ is an anchor made of galvanised steel or made of stainless steel which is placed into a drilled hole and anchored by torque-controlled expansion. The following anchor types are covered:

- Anchor type W-HAZ-B with threaded bolt,
- Anchor type W-HAZ-S with hexagon head screw,
- Anchor type W-HAZ-SK with countersunk washer and countersunk screw.

The product description is given in Annex A.

2 Specification of the intended use in accordance with the applicable European Assessment Document

The performances given in Section 3 are only valid if the anchor is used in compliance with the specifications and conditions given in Annex B.

The verifications and assessment methods on which this European Technical Assessment is based lead to the assumption of a working life of the anchor of at least 50 years. The indications given on the working life cannot be interpreted as a guarantee given by the producer, but are to be regarded only as a means for choosing the right products in relation to the expected economically reasonable working life of the works.

3 Performance of the product and references to the methods used for its assessment

3.1 Mechanical resistance and stability (BWR 1)

Essential characteristic	Performance
Characteristic resistance to tension load (static and quasi-static loading)	See Annex B3, B4, C1 to C4
Characteristic resistance to shear load (static and quasi-static loading)	See Annex C5 to C6
Characteristic resistance for seismic performance category C1 and C2	See Annex C7 to C8
Displacements	See Annex C10 to C11
Durability	See Annex B1

3.2 Safety in case of fire (BWR 2)

Essential characteristic	Performance
Reaction to fire	Class A1
Resistance to fire	See Annex C9

4 Assessment and verification of constancy of performance (AVCP) system applied, with reference to its legal base

In accordance with the European Assessment Document EAD 330232-00-0601 the applicable European legal act is: [96/582/EC].

The system to be applied is: 1

5 Technical details necessary for the implementation of the AVCP system, as provided for in the applicable European Assessment Document

Technical details necessary for the implementation of the AVCP system are laid down in the control plan deposited with Deutsches Institut für Bautechnik.

Issued in Berlin on 28 January 2021 by Deutsches Institut für Bautechnik

Dipl.-Ing. Beatrix Wittstock
Head of Section

beglaubigt:
Baderschneider

Würth High-Performance Anchor W-HAZ

Anchor type W-HAZ-B with threaded bolt

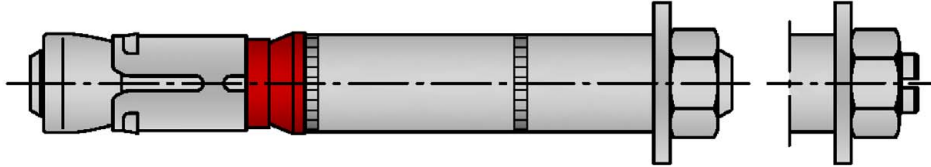

W-HAZ-B (M6-M24)
W-HAZ-B (M8-M16) A4

Anchor type W-HAZ-S with hexagon head screw

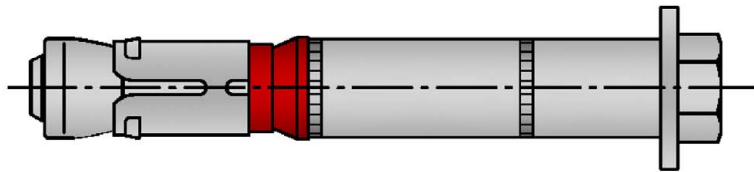

W-HAZ-S (M6-M24)
W-HAZ-S (M8-M16) A4

Anchor type W-HAZ-SK with countersunk washer and countersunk screw

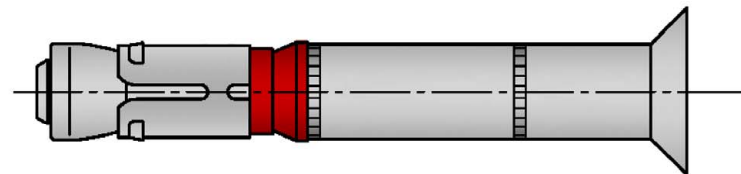

W-HAZ-SK (M6-M12)
W-HAZ-SK (M8-M12) A4

Installation condition

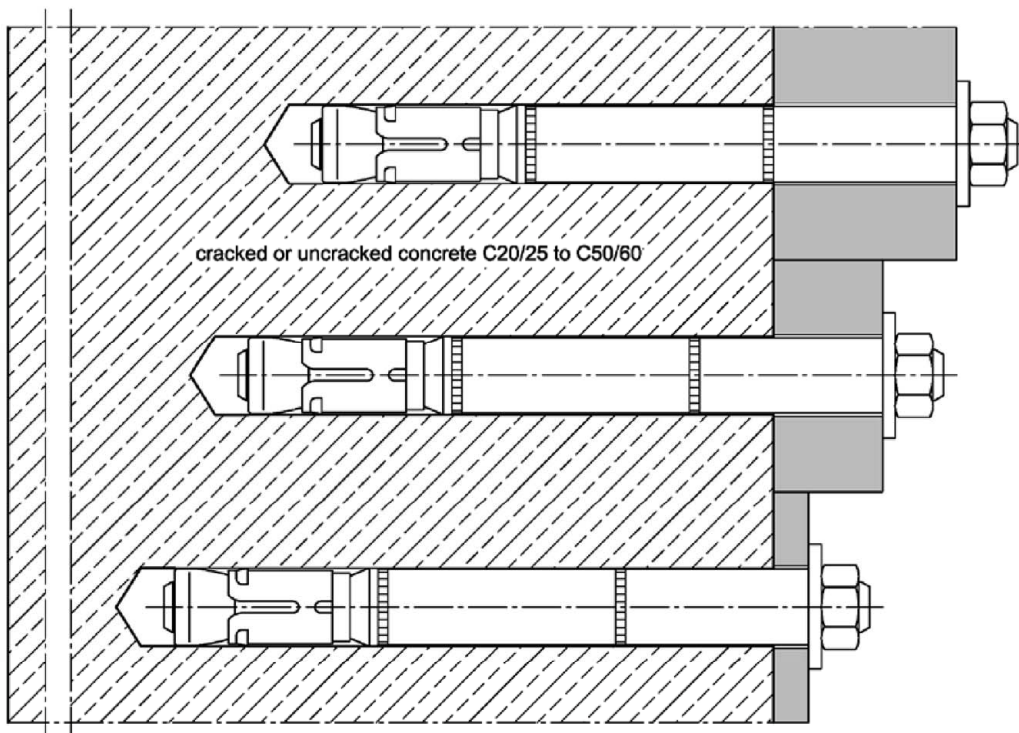

Würth High-Performance Anchor W-HAZ

Product description

Product and installation situation

Annex A1

W-HAZ-B

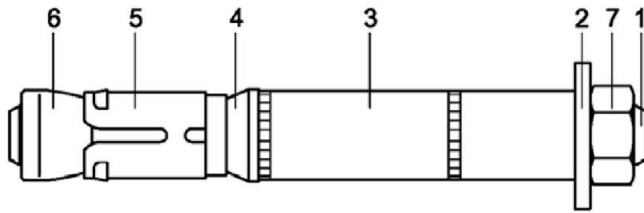

W-HAZ-S

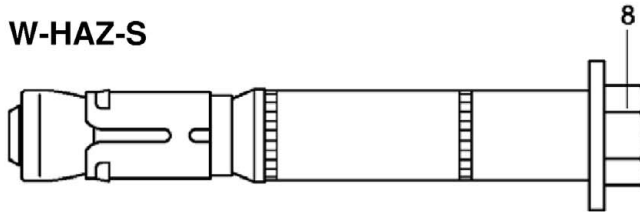

W-HAZ-SK

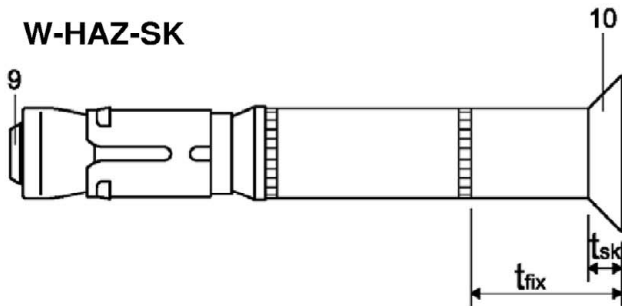

Marking:

- expansion sleeve:
- Identifying mark of manufacturing plant ◇
 - additional marking of stainless steel A4 A4
 - Anchor identity (alternatively on distance sleeve) W-HAZ
 - size of thread (alternatively M10 on distance sleeve)

- Distance sleeve:
- Diameter 15
 - max. thickness of fixture $t_{fix,max}$ for $h_{ef,min}$ 25
 - additional marking for countersunk version SK

marking on the washer of anchor size W-HAZ 24/M16L L

Table A1: Designation of Anchor parts and materials

Part	Designation	Materials galvanized $\geq 5 \mu\text{m}$, acc. To EN ISO 4042:1999	Stainless steel A4
1	Threaded bolt	Steel, Strength class 8.8, EN ISO 898-1:2013	Stainless steel, 1.4401, 1.4404 or 1.4571, EN 10088:2014
2	Washer	Steel, EN 10139:2016	Stainless steel, EN 10088:2014
3	Distance sleeve	Steel tube EN 10305-2:2016, EN 10305-3:2016;	Steel tube stainless steel, 1.4401, 1.4404 or 1.4571; EN 10217-7:2014, EN 10216-5:2013
4	Ring	Polyethylene	Polyethylene
5	Expansion sleeve	Steel, EN 10139:2016	Stainless steel, 1.4401, 1.4404 or 1.4571, EN 10088:2014
6	Threaded cone	Steel EN 10083-2:2006	Stainless steel, 1.4401, 1.4404 or 1.4571, EN 10088:2014
7	Hexagon nut	Steel, Strength class 8, EN ISO 898-2:2012	Stainless steel, strength class 70, EN ISO 3506-2:2009
8	Hexagon head screw	Steel, Strength class 8.8, EN ISO 898-1:2013	Stainless steel, strength class 70, EN ISO 3506-1:2009
9	Countersunk screw	Steel, Strength class 8.8, EN ISO 898-1:2013	Stainless steel, strength class 70, EN ISO 3506-1:2009
10	Countersunk washer	Steel, EN 10083-2:2006	Stainless steel, 1.4401, 1.4404 or 1.4571, EN 10088:2014, zinc plated

Würth High-Performance Anchor W-HAZ

Product description
Marking and materials

Annex A2

Specification of intended use

High-Performance Anchor W-HAZ/S, steel zinc plated	10/M6	12/M8	15/M10	18/M12	24/M16	24/ M16L	28/M20	32/M24
Static or quasi-static action	✓							
Seismic action (W-HAZ-B and W-HAZ-S)	-	C1 + C2						
Seismic action (W-HAZ-SK)	-	C1 + C2				-		
Fire exposure	R 30 ... R 120							
High-Performance Anchor W-HAZ/A4, stainless steel A4		12/M8	15/M10	18/M12	24/M16			
Static or quasi-static action	✓							
Seismic action (W-HAZ-B and W-HAZ-S)	C1 + C2							
Seismic action (W-HAZ-SK)	C1 + C2				-			
Fire exposure	R30 ... R120							

Base materials:

- Cracked and uncracked concrete
- Compacted, reinforced or unreinforced normal weight concrete (without fibers) according to EN 206:2013 + A1:2016
- Strength classes C20/25 to C50/60 according to EN 206:2013 + A1:2016

Use conditions (Environmental conditions):

- Structures subject to dry internal conditions (zinc plated steel or stainless steel).
- Structures subject to external atmospheric exposure (including industrial and marine environment) and to permanently damp internal conditions, if no particular aggressive conditions exist (stainless steel).

Note: Particular aggressive conditions are e.g. permanent, alternating immersion in seawater or the splash zone of seawater, chloride atmosphere of indoor pools or atmosphere with extreme chemical pollution (e.g. in desulphurization plants or road tunnels where de-icing materials are used.)

Design:

- Anchorages are designed under the responsibility of an engineer experienced in anchorages and concrete work.
- Verifiable calculation notes and drawings are prepared taking account of the loads to be anchored. The position of the Anchor is indicated on the design drawings (e.g. position of the Anchor relative to reinforcement or to supports, etc.).
- Design according to EN 1992-4:2018 and Technical Report TR055

Installation:

- Anchor installation carried out by appropriately qualified personnel and under the obligation of the person responsible for technical matters on site.
- Compliance with the effective anchorage depth. For fastenings with anchorage depths $h_{ef} > h_{ef,min}$ the usable thickness of fixture is reduced by $h_{ef} - h_{ef,min}$.
- Use as supplied by the manufacturer without replacing individual parts.
- Drilling of hole only by hammer drilling (use of vacuum drill bits is admissible)

Würth High-Performance Anchor W-HAZ

Intended use
Specification of intended use

Annex B1

Setting position

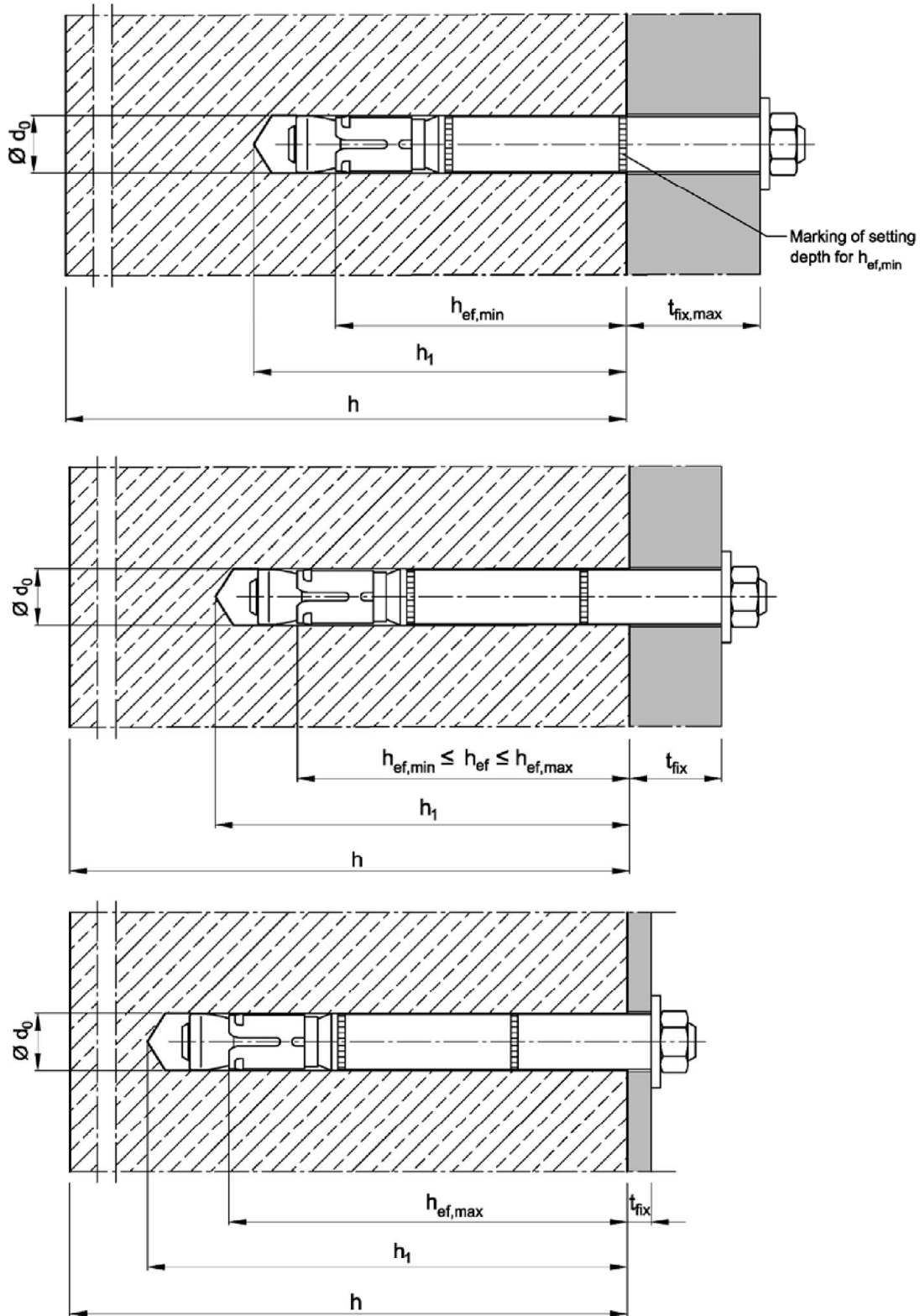

Würth High-Performance Anchor W-HAZ

Intended use
Installation situation

Annex B2

Table B1: Installation parameters, steel zinc plated

Anchor size			10/M6	12/M8	15/M10	18/M12	24/M16	24/ M16L	28/M20	32/M24	
Size of thread		[-]	M6	M8	M10	M12	M16	M16	M20	M24	
Minimum effective anchorage depth	$h_{ef,min}$	[mm]	50	60	71	80	100	115	125	150	
Maximum effective anchorage depth	$h_{ef,max}$	[mm]	76	100	110	130	114	150	185	210	
Nominal diameter of drill bit	$d_0 =$	[mm]	10	12	15	18	24	24	28	32	
Cutting diameter of drill bit	$d_{cut} \leq$	[mm]	10,45	12,5	15,5	18,5	24,55	24,55	28,55	32,7	
Depth of drill hole	$h_1 \geq$	[mm]	$h_{ef} + 15$	$h_{ef} + 20$	$h_{ef} + 24$	$h_{ef} + 25$	$h_{ef} + 30$	$h_{ef} + 30$	$h_{ef} + 35$	$h_{ef} + 30$	
Diameter of clearance hole in the fixture	$d_f \leq$	[mm]	12	14	17	20	26	26	31	35	
Thickness of countersunk washer W-HAZ-SK	t_{sk}	[mm]	4	5	6	7	-	-	-	-	
Minimum thickness of fixture W-HAZ-SK	$t_{fix min}^{2)}$	[mm]	8	10	14	18	-	-	-	-	
Installation torque	W-HAZ-B	T_{inst}	[Nm]	15	30	50	80	160	160	280	280
	W-HAZ-S										
	W-HAZ-SK	T_{inst}	[Nm]	10	25	55	70	-	-	-	-
Minimum thickness of member	h_{min}	[mm]	$h_{ef} + 50$	$h_{ef} + 60$	$h_{ef} + 69$	$h_{ef} + 80$	$h_{ef} + 100$	$h_{ef} + 115$	$h_{ef} + 125$	$h_{ef} + 150$	
cracked concrete											
Minimum spacing ^{1) 3)}	s_{min}	[mm]	50	50	60	70	100	100	125	150	
	for $c \geq$	[mm]	50	80	120	140	180	180	300	300	
Minimum edge distance ^{1) 3)}	c_{min}	[mm]	50	55	60	70	100	100	200	150	
	for $s \geq$	[mm]	50	100	120	160	220	220	350	300	
uncracked concrete											
Minimum spacing ^{1) 3)}	s_{min}	[mm]	50	60	60	70	100	100	125	150	
	for $c \geq$	[mm]	80	100	120	140	180	180	300	300	
Minimum edge distance ^{1) 3)}	c_{min}	[mm]	50	60	60	70	100	100	200	150	
	for $s \geq$	[mm]	100	120	120	160	220	220	350	300	

¹⁾ Intermediate values by linear interpolation

²⁾ Depending on the existing shear load, the thickness of the fixture may be reduced to the thickness of the countersunk washer t_{sk} (see Annex A2). It must be verified that the present shear load can be transferred completely into the distance sleeve (bearing of hole).

³⁾ For fire exposure from more than one side $c \geq 300$ mm or $c_{min} \geq 300$ mm applies.

Würth High-Performance Anchor W-HAZ

Intended use
Installation parameters, **steel zinc plated**

Annex B3

Table B2: Installation parameters, stainless steel A4

Anchor size			12/M8	15/M10	18/M12	24/M16
Size of thread		[-]	M8	M10	M12	M16
Minimum effective anchorage depth	$h_{ef,min}$	[mm]	60	71	80	100
Maximum effective anchorage depth	$h_{ef,max}$	[mm]	100	110	130	150
Nominal diameter of drill bit	$d_0 =$	[mm]	12	15	18	24
Cutting diameter of drill bit	$d_{cut} \leq$	[mm]	12,5	15,5	18,5	24,55
Depth of drill hole	$h_1 \geq$	[mm]	$h_{ef} + 20$	$h_{ef} + 24$	$h_{ef} + 25$	$h_{ef} + 30$
Diameter of clearance hole in the fixture	$d_f \leq$	[mm]	14	17	20	26
Thickness of countersunk washer W-HAZ-SK	t_{sk}	[mm]	5	6	7	-
Minimum thickness of fixture W-HAZ-SK	$t_{fix,min}^{2)}$	[mm]	10	14	18	-
Installation torque	$T_{inst} (W-HAZ-B)$	[Nm]	35	55	90	170
	$T_{inst} (W-HAZ-S)$	[Nm]	30	50	80	170
	$T_{inst} (W-HAZ-SK)$	[Nm]	17,5	42,5	50	-
Minimum thickness of member	h_{min}	[mm]	$h_{ef} + 60$	$h_{ef} + 69$	$h_{ef} + 80$	$h_{ef} + 100$
cracked concrete						
Minimum spacing ^{1) 3)}	s_{min}	[mm]	50	60	70	80
	for $c \geq$	[mm]	80	120	140	180
Minimum edge distance ^{1) 3)}	c_{min}	[mm]	50	60	70	80
	for $s \geq$	[mm]	80	120	160	200
uncracked concrete						
Minimum spacing ^{1) 3)}	s_{min}	[mm]	50	60	70	80
	for $c \geq$	[mm]	80	120	140	180
Minimum edge distance ^{1) 3)}	c_{min}	[mm]	50	85	70	180
	for $s \geq$	[mm]	80	185	160	80

¹⁾ Intermediate values by linear interpolation

²⁾ Depending on the existing shear load, the thickness of the fixture may be reduced to the thickness of the countersunk washer t_{sk} (see Annex A2). It must be verified that the present shear load can be transferred completely into the distance sleeve (bearing of hole).

³⁾ For fire exposure from more than one side $c \geq 300$ mm or $c_{min} \geq 300$ mm applies.

Würth High-Performance Anchor W-HAZ

Intended use
Installation parameters, **stainless steel A4**

Annex B4

Installation instructions

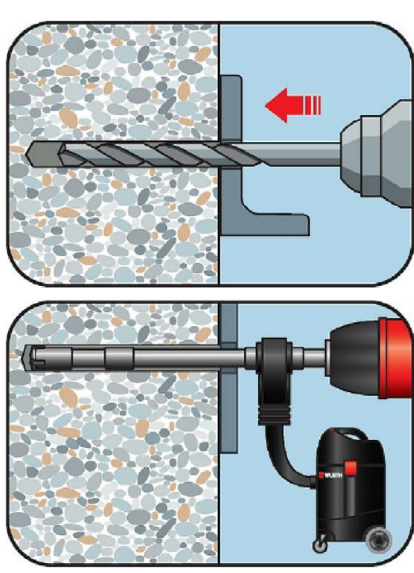
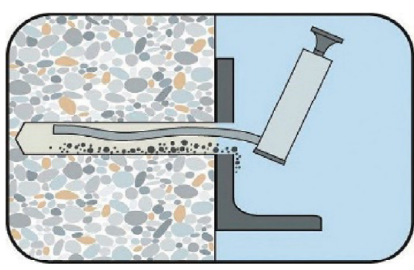
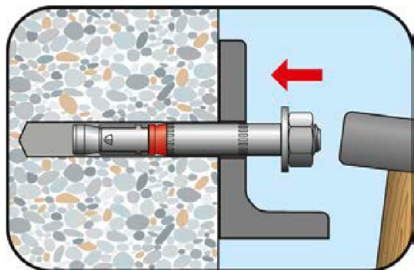
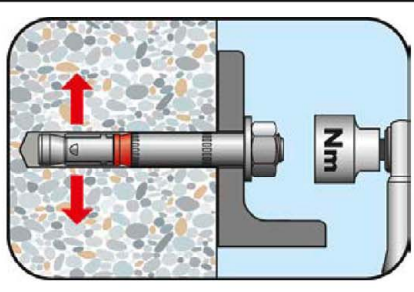
<p>1</p>		<p>Drill hole perpendicular to concrete surface. If using a vacuum drill bit, proceed with step 3.</p>
<p>2</p>		<p>Blow out dust. Alternatively vacuum clean down to the bottom of the hole.</p>
<p>3</p>		<p>Drive in Anchor.</p>
<p>4</p>		<p>Apply installation torque T_{inst}.</p>

Würth High-Performance Anchor W-HAZ

Intended use
Installation instructions

Annex B5

Table C1: Characteristic values for **tension load, cracked concrete,** static or quasi-static action, **steel zinc plated**

Anchor size			10/M6	12/M8	15/M10	18/M12	24/M16	24/ M16L	28/M20	32/M24
Installation factor	γ_{inst}	[-]	1,0							
Steel failure										
Characteristic resistance	$N_{Rk,s}$	[kN]	16	29	46	67	126	126	196	282
Partial factor	γ_{Ms}	[-]	1,5							
Pull-out failure										
Characteristic resistance in cracked concrete C20/25	$N_{Rk,p}$	[kN]	5	12	16	25	36	44	50	65
Increasing factor for $N_{Rk,p}$	ψ_C	[-]	$\left(\frac{f_{ck}}{20}\right)^{0,5}$							
Concrete cone failure										
Minimum effective anchorage depth	$h_{ef,min}$	[mm]	50	60	71	80	100	115	125	150
Maximum effective anchorage depth	$h_{ef,max}$	[mm]	76	100	110	130	114	150	185	210
Factor for cracked concrete	$k_{cr,N}$	[-]	7,7							

Würth High-Performance Anchor W-HAZ

Performance

Characteristic values for **tension load, cracked concrete,** static or quasi-static action, **steel zinc plated**

Annex C1

Table C2: Characteristic values for **tension load, cracked concrete,** static or quasi-static action, **stainless steel A4**

Anchor size			12/M8	15/M10	18/M12	24/M16
Installation factor	γ_{inst}	[-]	1,0			
Steel failure						
W-HAZ-B						
Characteristic resistance	$N_{Rk,s}$	[kN]	26	41	60	110
Partial factor	γ_{Ms}	[-]	1,5			
W-HAZ-S and W-HAZ-SK						
Characteristic resistance	$N_{Rk,s}$	[kN]	26	41	60	110
Partial factor	γ_{Ms}	[-]	1,87			
Pull-out failure						
Characteristic resistance in cracked concrete C20/25	$N_{Rk,p}$	[kN]	9	16	25	36
Increasing factor for $N_{Rk,p}$	ψ_C	[-]	$\left(\frac{f_{ck}}{20}\right)^{0,5}$			
Concrete cone failure						
Minimum effective anchorage depth	$h_{ef,min}$	[mm]	60	71	80	100
Maximum effective anchorage depth	$h_{ef,max}$	[mm]	100	110	130	150
Factor for cracked concrete	$k_{cr,N}$	[-]	7,7			

Würth High-Performance Anchor W-HAZ

Performance

Characteristic values for **tension load, cracked concrete,** static or quasi-static action, **stainless steel A4**

Annex C2

Table C3: Characteristic values for tension load, uncracked concrete, static or quasi-static action, steel zinc plated

Anchor size			10/M6	12/M8	15/M10	18/M12	24/M16	24/ M16L	28/M20	32/M24	
Installation factor	γ_{inst}	[-]	1,0								
Steel failure											
Characteristic resistance	$N_{Rk,s}$	[kN]	16	29	46	67	126	126	196	282	
Partial factor	γ_{Ms}	[-]	1,5								
Pull-out failure											
Characteristic resistance in uncracked concrete C20/25	$N_{Rk,p}$	[kN]	17	20	30	36	50	1)	70	1)	
Increasing factor for $N_{Rk,p}$	ψ_C	[-]	$\left(\frac{f_{ck}}{20}\right)^{0,5}$					-	$\left(\frac{f_{ck}}{20}\right)^{0,5}$		
Splitting failure (The higher resistance of case 1 and case 2 may be applied)											
Case 1											
Characteristic resistance in uncracked concrete C20/25	$N^0_{Rk,sp}$	[kN]	12	16	25	30	40	70	50	70	
Edge distance	$c_{cr,sp}$	[mm]	1,5 h_{ef}								
Increasing factor for $N^0_{Rk,sp}$	ψ_C	[-]	$\left(\frac{f_{ck}}{20}\right)^{0,5}$								
Case 2											
Characteristic resistance in uncracked concrete	$N^0_{Rk,sp}$	[kN]	$\min(N_{Rk,p}; N^0_{Rk,c})$								
Edge distance	$c_{cr,sp}$	[mm]	2,5 h_{ef}					1,5 h_{ef}	2,5 h_{ef}	2 h_{ef}	
Concrete cone failure											
Minimum effective anchorage depth	$h_{ef,min}$	[mm]	50	60	71	80	100	115	125	150	
Maximum effective anchorage depth	$h_{ef,max}$	[mm]	76	100	110	130	114	150	185	210	
Edge distance	$c_{cr,N}$	[mm]	1,5 h_{ef}								
Factor for uncracked concrete	$k_{ucr,N}$	[-]	11,0								

1) $N_{Rk,p} = N^0_{Rk,c}$ calculated with $h_{ef,min}$

Würth High-Performance Anchor W-HAZ

Performance
Characteristic values for **tension load, uncracked concrete**, static or quasi-static action,
steel zinc plated

Annex C3

Table C4: Characteristic values for **tension load, uncracked concrete**, static or quasi-static action, **stainless steel A4**

Anchor size			12/M8	15/M10	18/M12	24/M16
Installation factor	γ_{inst}	[-]	1,0			
Steel failure						
W-HAZ-B						
Characteristic resistance	$N_{Rk,s}$	[kN]	26	41	60	110
Partial factor	γ_{Ms}	[-]	1,5			
W-HAZ-S and W-HAZ-SK						
Characteristic resistance	$N_{Rk,s}$	[kN]	26	41	60	110
Partial factor	γ_{Ms}	[-]	1,87			
Pull-out failure						
Characteristic resistance in uncracked concrete C20/25	$N_{Rk,p}$	[kN]	16	25	35	50
Increasing factor for $N_{Rk,p}$	ψ_C	[-]	$\left(\frac{f_{ck}}{20}\right)^{0,5}$			
Splitting failure						
Edge distance	$c_{Cr,sp}$	[mm]	180	235	265	300
Concrete cone failure						
Minimum effective anchorage depth	$h_{ef,min}$	[mm]	60	71	80	100
Maximum effective anchorage depth	$h_{ef,max}$	[mm]	100	110	130	150
Edge distance	$c_{Cr,N}$	[mm]	1,5 h_{ef}			
Factor for uncracked concrete	$k_{Ucr,N}$	[-]	11,0			

Würth High-Performance Anchor W-HAZ

Performance
Characteristic values for **tension loads, uncracked concrete**, static or quasi-static action, **stainless steel A4**

Annex C4

Table C5: Characteristic values for **shear load**, static or quasi-static action, **steel zinc plated**

Anchor size			10/M6	12/M8	15/M10	18/M12	24/M16	24/ M16L	28/M20	32/M24
Steel failure without lever arm										
W-HAZ-B										
Characteristic resistance	$V_{Rk,s}^0$	[kN]	16	25	36	63	91	91	122	200
Ductility factor	k_7	[-]	1,0							
Partial factor	γ_{Ms}	[-]	1,25							
W-HAZ-S and W-HAZ-SK										
Characteristic resistance	$V_{Rk,s}^0$	[kN]	18	30	48	73	126	126	150	200
Ductility factor	k_7	[-]	1,0							
Partial factor	γ_{Ms}	[-]	1,25							
Steel failure with lever arm										
W-HAZ-B, W-HAZ-S and W-HAZ-SK										
Anchorage depth	$h_{ef,min} \geq$	[mm]	50	60	71	80	100	115	125	150
Characteristic bending resistance	$M_{Rk,s}^0$	[Nm]	12	30	60	105	266	266	519	898
Partial factor	γ_{Ms}	[-]	1,25							
Anchorage depth	$h_{ef} \geq$	[mm]	64	73	90	106	138	138	158	188
Characteristic bending resistance	$M_{Rk,s}^0$	[Nm]	40	58	119	234	529	529	847	1343
Partial factor	γ_{Ms}	[-]	1,25							
Concrete pry-out failure										
Pry-out factor	k_8	[-]	1,8 ¹⁾	2,0						
Concrete edge failure										
Effective length of Anchor in shear loading	l_f	[mm]	h_{ef}							
Outside diameter of Anchor	d_{nom}	[mm]	10	12	15	18	24	24	28	32

¹⁾ $k_8 = 2,0$ for $h_{ef} \geq 60$ mm

Würth High-Performance Anchor W-HAZ

Performance
Characteristic values for **shear load**, static or quasi-static action,
steel zinc plated

Annex C5

Table C6: Characteristic values for **shear load**, static or quasi-static action, **stainless steel A4**

Anchor size			12/M8	15/M10	18/M12	24/M16
Steel failure without lever arm						
Characteristic resistance	$V_{Rk,s}^0$	[kN]	24	37	62	92
W-HAZ-B						
Ductility factor	k_7	[-]	1,0			
Partial factor	γ_{Ms}	[-]	1,25			
W-HAZ-S						
Ductility factor	k_7	[-]	1,0			
Partial factor	γ_{Ms}	[-]	1,36			
W-HAZ-SK						
Ductility factor	k_7	[-]	0,8			-
Partial factor	γ_{Ms}	[-]	1,36			-
Steel failure with lever arm						
Anchorage depth	$h_{ef,min} \geq$	[mm]	60	71	80	100
Characteristic bending resistance	$M_{Rk,s}^0$	[Nm]	26	52	92	232
W-HAZ-B						
Partial factor	γ_{Ms}	[-]	1,25			
W-HAZ-S and W-HAZ-SK						
Partial factor	γ_{Ms}	[-]	1,56			
W-HAZ-B, W-HAZ-S and W-HAZ-SK						
Anchorage depth	$h_{ef} \geq$	[mm]	73	90	106	138
Characteristic bending resistance	$M_{Rk,s}^0$	[Nm]	103	211	374	847
Partial factor	γ_{Ms}	[-]	1,25			
Concrete pry-out failure						
Pry-out factor	k_8	[-]	2,0			
Concrete edge failure						
Effective length of Anchor in shear loading	l_f	[mm]	h_{ef}			
Outside diameter of Anchor	d_{nom}	[mm]	12	15	18	24

Würth High-Performance Anchor W-HAZ

Performance
Characteristic values for **shear load**, static or quasi-static action,
stainless steel A4

Annex C6

Table C7: Characteristic values for **seismic action, Category C1 and C2, steel zinc plated**

Anchor size			12/M8	15/M10	18/M12	24/M16	24/M16L	28/M20	32/M24
Tension load									
Installation factor	γ_{inst}	[-]	1,0						
Steel failure									
Characteristic resistance category C1	$N_{Rk,s,eq,C1}$	[kN]	29	46	67	126	126	196	282
Characteristic resistance category C2	$N_{Rk,s,eq,C2}$	[kN]	29	46	67	126	126	196	282
Partial factor	γ_{Ms}	[-]	1,5						
Pull-out failure									
Characteristic resistance category C1	$N_{Rk,p,eq,C1}$	[kN]	12	16	25	36	44,4	50,3	63,3
Characteristic resistance category C2	$N_{Rk,p,eq,C2}$	[kN]	5,4	16,4	22,6	29,0	41,2	43,6	63,3
Shear load									
Steel failure without lever arm									
W-HAZ-B									
Characteristic resistance category C1	$V_{Rk,s,eq,C1}$	[kN]	18,0	27,1	43,4	51,9	51,9	96,4	160,1
Characteristic resistance category C2	$V_{Rk,s,eq,C2}$	[kN]	12,7	20,5	31,5	50,1	50,1	67,1	108,1
W-HAZ-S									
Characteristic resistance category C1	$V_{Rk,s,eq,C1}$	[kN]	18,0	27,1	43,4	51,9	51,9	96,4	160,1
Characteristic resistance category C2	$V_{Rk,s,eq,C2}$	[kN]	12,7	20,5	31,5	69,3	69,3	67,1	108,1
W-HAZ-SK									
Characteristic resistance category C1	$V_{Rk,s,eq,C1}$	[kN]	25,2	36,5	50,4	-	-	-	-
Characteristic resistance category C2	$V_{Rk,s,eq,C2}$	[kN]	19,2	29,3	39,4	-	-	-	-
Factor for annular gap	α_{gap}	[-]	0,5						
Partial factor	γ_{Ms}	[-]	1,25						

Würth High-Performance Anchor W-HAZ

Performance
Characteristic values for **seismic action, steel zinc plated**

Annex C7

Table C8: Characteristic values for **seismic action, Category C1 and C2, stainless steel A4**

Anchor size			12/M8	15/M10	18/M12	24/M16
Tension load						
Installation factor	γ_{inst}	[-]	1,0			
Steel failure						
Characteristic resistance, category C1	$N_{Rk,s,eq,C1}$	[kN]	26	41	60	110
Characteristic resistance, category C2	$N_{Rk,s,eq,C2}$	[kN]	26	41	60	110
Partial factor W-HAZ-B	γ_{Ms}	[-]	1,5			
Partial factor W-HAZ-S and W-HAZ-SK	γ_{Ms}	[-]	1,87			
Pull-out failure						
Characteristic resistance, category C1	$N_{Rk,p,eq,C1}$	[kN]	9	16	26	36
Characteristic resistance, category C2	$N_{Rk,p,eq,C2}$	[kN]	4,8	16,5	24,8	44,5
Shear load						
Steel failure without lever arm						
W-HAZ-B						
Characteristic resistance, category C1	$V_{Rk,s,eq,C1}$	[kN]	9,6	13,3	25,4	75,4
Characteristic resistance, category C2	$V_{Rk,s,eq,C2}$	[kN]	9,7	14,0	18,0	32,2
Partial factor	γ_{Ms}	[-]	1,25			
W-HAZ-S						
Characteristic resistance, category C1	$V_{Rk,s,eq,C1}$	[kN]	9,6	13,3	25,4	75,4
Characteristic resistance, category C2	$V_{Rk,s,eq,C2}$	[kN]	9,7	14,0	18,0	32,2
Partial factor	γ_{Ms}	[-]	1,36			
W-HAZ-SK						
Characteristic resistance, category C1	$V_{Rk,s,eq,C1}$	[kN]	11,5	23,3	31,6	-
Characteristic resistance, category C2	$V_{Rk,s,eq,C2}$	[kN]	10,8	17,4	15,4	-
Partial factor	γ_{Ms}	[-]	1,36			-
Factor for annular gap	α_{gap}	[-]	0,5			

Würth High-Performance Anchor W-HAZ

Performance
Characteristic values for **seismic action, stainless steel A4**

Annex C8

Table C9: Characteristic values under **fire exposure** in cracked and uncracked concrete C20/25 to C50/60

Anchor size		10/M6	12/M8	15/M10	18/M12	24/M16	24/ M16L	28/M20	32/M24	
Tension load										
Steel failure										
Steel zinc plated										
Characteristic resistance	R30	$N_{Rk,s,fi}$ [kN]	1,0	1,9	4,3	6,3	11,6	18,3	26,3	
	R60		0,8	1,5	3,2	4,6	8,6	13,5	19,5	
	R90		0,6	1,0	2,1	3,0	5,0	7,7	12,6	
	R120		0,4	0,8	1,5	2,0	3,1	4,9	9,2	
Stainless steel A4										
Characteristic resistance	R30	$N_{Rk,s,fi}$ [kN]	-	6,1	10,2	15,7	29,2	-	-	-
	R60		-	4,4	7,3	11,1	20,6	-	-	-
	R90		-	2,6	4,3	6,4	12,0	-	-	-
	R120		-	1,8	2,8	4,1	7,7	-	-	-
Shear load										
Steel failure without lever arm										
Steel zinc plated										
Characteristic resistance	R30	$V_{Rk,s,fi}$ [kN]	1,0	1,9	4,3	6,3	11,6	18,3	26,3	
	R60		0,8	1,5	3,2	4,6	8,6	13,5	19,5	
	R90		0,6	1,0	2,1	3,0	5,0	7,7	12,6	
	R120		0,4	0,8	1,5	2,0	3,1	4,9	9,2	
Stainless steel A4										
Characteristic resistance	R30	$V_{Rk,s,fi}$ [kN]	-	14,3	22,7	32,8	61,0	-	-	-
	R60		-	11,1	17,6	25,5	47,5	-	-	-
	R90		-	7,9	12,6	18,3	34,0	-	-	-
	R120		-	6,3	10,0	14,6	27,2	-	-	-
Steel failure with lever arm										
Steel zinc plated										
Characteristic bending resistance	R30	$M^0_{Rk,s,fi}$ [Nm]	0,8	2,0	5,6	9,7	24,8	42,4	83,6	
	R60		0,6	1,5	4,1	7,2	18,3	29,8	61,9	
	R90		0,4	1,0	2,7	4,7	11,9	17,1	40,1	
	R120		0,3	0,8	1,9	3,1	6,6	10,7	29,2	
Stainless steel A4										
Characteristic bending resistance	R30	$M^0_{Rk,s,fi}$ [Nm]	-	6,2	13,2	24,4	61,8	-	-	-
	R60		-	4,5	9,4	17,2	43,6	-	-	-
	R90		-	2,7	5,6	10,0	25,3	-	-	-
	R120		-	1,8	3,6	6,4	16,2	-	-	-

The characteristic resistance for pull-out $N_{Rk,p,fi}$ shall be calculated according to EN 1992-4:2018.

Würth High-Performance Anchor W-HAZ

Performance
Characteristic values under **fire exposure**

Annex C9

Table C10: Displacements under tension and shear load, **steel zinc plated**

Anchor size			10/ M6	12/ M8	15/ M10	18/ M12	24/ M16	24 /M16L	28/ M20	32/ M24
Tension load										
Tension load in cracked concrete	N	[kN]	2,4	5,7	7,6	12,3	17,1	21,1	24	26,2
Displacement	δ_{N0}	[mm]	0,5	0,5	0,5	0,7	0,8	0,7	0,9	1,4
	$\delta_{N\infty}$	[mm]	2,0	2,0	1,3	1,3	1,3	1,3	1,4	1,9
Tension load in uncracked concrete	N	[kN]	8,5	9,5	14,3	17,2	24	29,6	34	43
Displacement	δ_{N0}	[mm]	0,8	1,0	1,1		1,3		0,3	0,7
	$\delta_{N\infty}$	[mm]	3,4		1,7		2,3		1,4	0,7
Seismic action C2										
Displacement for DLS	$\delta_{N,eq}$ (DLS)	[mm]	-	3,3	3,0	5,0	3,0	3,0	4,0	5,3
Displacement for ULS	$\delta_{N,eq}$ (ULS)	[mm]	-	12,2	11,3	16,0	9,2	9,2	13,8	12,4
Shear load										
W-HAZ-B										
Shear load in cracked and uncracked concrete	V	[kN]	9,1	14	20,7	35,1	52,1	52,1	77	86,6
Displacement	δ_{V0}	[mm]	2,5	2,1	2,7	3,0	5,1	5,1	4,3	10,5
	$\delta_{V\infty}$	[mm]	3,8	3,1	4,1	4,5	7,6	7,6	6,5	15,8
Seismic action C2										
Displacement for DLS	$\delta_{V,eq}$ (DLS)	[mm]	-	2,3	3,1	3,0	2,6	2,6	1,6	6,1
Displacement for ULS	$\delta_{V,eq}$ (ULS)	[mm]	-	4,8	6,4	6,1	6,6	6,6	4,8	9,5
W-HAZ-S										
Shear load in cracked and uncracked concrete	V	[kN]	10,1	17,1	27,5	41,5	72	72	77	86,6
Displacement	δ_{V0}	[mm]	2,9	2,5	3,6	3,5	7,0	7,0	4,3	10,5
	$\delta_{V\infty}$	[mm]	4,4	3,8	5,4	5,3	10,5	10,5	6,5	15,8
Seismic action C2										
Displacement for DLS	$\delta_{V,eq}$ (DLS)	[mm]	-	2,3	3,1	3,0	3,3	3,3	1,6	6,1
Displacement for ULS	$\delta_{V,eq}$ (ULS)	[mm]	-	4,8	6,4	6,1	8,2	8,2	4,8	9,5
W-HAZ-SK										
Shear load in cracked and uncracked concrete	V	[kN]	10,1	17,1	27,5	41,5	-	-	-	-
Displacement	δ_{V0}	[mm]	2,9	2,5	3,6	3,5	-	-	-	-
	$\delta_{V\infty}$	[mm]	4,4	3,8	5,4	5,3	-	-	-	-
Seismic action C2										
Displacement for DLS	$\delta_{V,eq}$ (DLS)	[mm]	-	3,1	3,9	3,9	-	-	-	-
Displacement for ULS	$\delta_{V,eq}$ (ULS)	[mm]	-	10,2	11,8	13,0	-	-	-	-

Würth High-Performance Anchor W-HAZ

Performance
Displacements under tension and shear load, **steel zinc plated**

Annex C10

Table C11: Displacements under tension and shear load, **stainless steel A4**

Anchor size			12/M8	15/M10	18/M12	24/M16
Tension load						
Tension load in cracked concrete	N	[kN]	4,3	7,6	12,1	17,0
Displacement	δ_{N0}	[mm]	0,5	0,5	1,3	0,5
	$\delta_{N\infty}$	[mm]	1,2	1,6	1,8	1,6
Tension load in uncracked concrete	N	[kN]	7,6	11,9	16,7	24,1
Displacement	δ_{N0}	[mm]	0,2	0,3	1,2	1,5
	$\delta_{N\infty}$	[mm]	1,1	1,1	1,1	1,1
Seismic action C2						
Displacement for DLS	$\delta_{N,eq (DLS)}$	[mm]	4,7	4,5	4,3	4,9
Displacement for ULS	$\delta_{N,eq (ULS)}$	[mm]	13,3	12,7	9,7	10,1
Shear load						
Shear load in cracked concrete	V	[kN]	13,9	21,1	34,7	50,8
Displacement	δ_{V0}	[mm]	3,4	4,9	4,8	6,7
	$\delta_{V\infty}$	[mm]	5,1	7,4	7,1	10,1
Seismic action C2						
W-HAZ-B and W-HAZ-S						
Displacement for DLS	$\delta_{V,eq (DLS)}$	[mm]	2,8	3,1	2,6	3,3
Displacement for ULS	$\delta_{V,eq (ULS)}$	[mm]	5,6	5,8	5,0	6,9
W-HAZ-SK						
Displacement for DLS	$\delta_{V,eq (DLS)}$	[mm]	2,5	2,8	2,9	-
Displacement for ULS	$\delta_{V,eq (ULS)}$	[mm]	5,8	5,9	6,9	-

Würth High-Performance Anchor W-HAZ

Performance
Displacements under tension and shear load, **stainless steel A4**

Annex C11