



ETA-Danmark A/S
Göteborg Plads 1
DK-2150 Nordhavn
Tel. +45 72 24 59 00
Fax +45 72 24 59 04
Internet www.etadanmark.dk

Authorised and notified according
to Article 29 of the Regulation (EU)
No 305/2011 of the European
Parliament and of the Council of 9
March 2011

MEMBER OF EOTA



European Technical Assessment ETA-13/0029 of 11/07/2017

General Part

Technical Assessment Body issuing the ETA and designated according to Article 29 of the Regulation (EU) No 305/2011: ETA-Danmark A/S

Trade name of the
construction product:

ASSY plus VG screw

Product family to which the
above construction product
belongs:

Self-tapping screws for use in wood-concrete slab kits

Manufacturer:

Adolf Würth GmbH & Co. KG
Reinhold Würth Strasse 12 – 17
D-74650 Künzelsau
Tel. +49 7940 15 0
Fax +49 7940 15 1000
Internet www.wuerth.com

Manufacturing plant:

Werk I, Werk II, Werk III

This European Technical
Assessment contains:

13 pages including 3 annexes which form an integral
part of the document

This European Technical
Assessment is issued in
accordance with Regulation
(EU) No 305/2011, on the
basis of:

European Assessment Document (EAD) no EAD
130090-00-0303 "Wood-concrete composite slab with
dowel-type fasteners"

This version replaces:

The ETA with the same number issued on 2013-01-29
and expiry on 2017-07-16

Translations of this European Technical Assessment in other languages shall fully correspond to the original issued document and should be identified as such.

Communication of this European Technical Assessment, including transmission by electronic means, shall be in full (excepted the confidential Annex(es) referred to above). However, partial reproduction may be made, with the written consent of the issuing Technical Assessment Body. Any partial reproduction has to be identified as such

II SPECIFIC PART OF THE EUROPEAN TECHNICAL ASSESSMENT

1 Technical description of product and intended use

Technical description of the product

This ETA is an assessment of the ASSY plus VG screw for wood-concrete composite slab kits. The assessment concerns use of the screws in composite slab kits, however, the holder of this ETA only delivers the screws. The diameter of the ASSY plus VG screws is either 8 mm or 10 mm, the length ranges between 150 mm and 800 mm. The shape and tolerances of the screws are given in Annex 3. ASSY plus VG screws with 10 mm diameter arranged under 30° between screw axis and joint line are always used together with FT-connectors.

NOTE. The FT-connector has not been assessed in its own right, but the assessments forming the basis for this ETA presumes that the FT-connector is used and the characteristic capacities indicated in the ETA are valid only if the ASSY plus VG screw is used together with the FT-connector.

The kits are individually designed to meet the requirements put on the works.

Adolf Würth GmbH & Co. KG delivers the ASSY plus VG screws and, where applicable, the FT-connectors, for the composite action to be used as kit components. The composite members may be prefabricated at factory, or they may be composed at the building site. The proper function of the wood-concrete composite slabs provides for the following components to be added in the factory or at the building site:

- Concrete slab, according to EN 1992-1-1, and national regulations either prefabricated or cast at the building site. The minimum concrete strength class is C20/25.
- In the case of concrete cast at the building site: formwork, e.g. timber boards or wood based panel. This is an optional intermediate layer between the concrete and the timber.
- In the case of concrete cast at the building site: lateral moulding along the edges of the slab.
- Timber members, e.g. glulam according to EN 14080, sawn softwood timber according to EN 14081-1, LVL according to EN 14374 or cross laminated timber according to ETA.

The concrete flange is loaded in compression or tension. The timber members are usually parallel or almost parallel.

This ETA covers screws for composite members with minimum concrete flange depths which comply with the

regulations on the slab depths in the place use (national regulations) but not less than 50 mm for 8 mm screws and 70 mm for 10 mm screws, and minimum timber member depths of 100 mm. The maximum concrete flange depth is 70 % of the timber member depth. Typical spans for the construction are up to 8 m with sawn softwood timber members, 10 m with LVL members and 14 m with glulam members but larger spans also are possible.

A typical composite member is shown in figure 1.1a of Annex 1. A typical screw is shown in figure 1.1d.

Specification of the intended use in accordance with the applicable European Assessment Document

ASSY plus VG screws are intended to be used in structural composite members such as floor, roof, or wall constructions in service classes 1 and 2 as defined in EN 1995-1-1 subject to static or quasi static loading. In addition, use class 3.1 as defined in EN 335-1 (exterior, above ground, protected) may be possible, as balconies depending on national provisions.

The verification and assessment methods on which this European Technical Assessment is based lead to the assumption of a working life of at least 50 years for ASSY plus VG screw.

The indications given on the working life cannot be interpreted as a guarantee given by the manufacturer, but are to be regarded only as a means for choosing the right product in relation to the expected economically reasonable working life of the works.

3 Performance of the product and references to the methods used for its assessment

Characteristic	Assessment of characteristic
3.1 Mechanical resistance and stability (BWR 1)*)	
Structural performance	<p>Wood-concrete composite slabs including ASSY plus VG screws are used and manufactured according to an individual design made by a structural engineer responsible for the design of works on a case by case basis. Wood-concrete composite floors may function as directly load bearing and structural bracing members. The structural performance of them shall be considered in accordance with the limit state design principles specified in Eurocodes.</p> <p>The performance of the composite slab is outside of this ETA.</p> <p>The screws are made of case hardened steel as specified in the control plan and corrosion protected with a zinc coating.</p> <p>Geometry of the screws is defined in Annex 3.</p> <p>Mechanical properties of ASSY plus VG screws and applicable creep and duration of load factors for composite members are given in Annex 2.</p>
3.2 Safety in case of fire (BWR 2)	
Reaction to fire	<p>ASSY plus VG screws including the zinc coating are classified non-combustible in accordance with EC Decision 2000/147/EC and fulfil the requirements of class A1 according to EN 13501-1: 2002.</p>
3.3 Hygiene, health and the environment (BWR 3)	
Influence on air quality	<p>The product does not contain/release dangerous substances specified in TR 034, dated March 2012.</p>

*) See additional information in section 3.9 – 3.10.

In addition to the specific clauses relating to dangerous substances contained in this European technical Assessment, there may be other requirements applicable to the products falling within its scope (e.g. transposed European legislation and national laws, regulations and administrative provisions). In order to meet the provisions of the Construction Products Regulation, these requirements need also to be complied with, when and where they apply.

3.9 General aspects

Adolf Würth GmbH & Co. KG delivers ASSY plus VG screws and FT-connectors intended to be component in wood-concrete composite slabs in accordance with the provisions of this European Technical Assessment. The ASSY plus VG screws and FT-connectors are manufactured in the factory in accordance with the provisions of this European Technical Assessment.

ASSY plus VG screws and FT-connectors shall be installed on the basis of a specific structural design for

each composite slab installation. Load bearing capacities to be used in the design are given in Annex 2.

The design also shall take into account any aspects regarding installation of the kit components, as any temporary bracing and supporting. Wood-concrete composite slabs shall be installed by appropriately qualified personnel, following the installation plan. Only ASSY plus VG screws and FT-connectors without any defects are allowed to be used. Before concrete is poured, the person responsible for the design of the works shall check the set of the ASSY plus VG screws and FT-connectors to be in accordance with the design.

The manufacturer shall ensure that the information of these provisions is given to those concerned.

3.10 Aspects related to the performance of the product

3.10.1 Corrosion protection in service class 1 and 2.
Durability of the finished composite slab is not covered by this ETA.

Durability of the ASSY plus VG screws is provided for by the protective zinc coating for a mean thickness of 5 μm

4 Assessment and verification of constancy of performance (AVCP)

4.1 AVCP system

According to the decision 2000/447/EC of the European Commission, the system(s) of assessment and verification of constancy of performance (see Annex V to Regulation (EU) No 305/2011) is 1.

5 Technical details necessary for the implementation of the AVCP system, as foreseen in the applicable EAD

Technical details necessary for the implementation of the AVCP system are laid down in the control plan deposited at ETA-Danmark prior to CE marking

Issued in Copenhagen on 2017-07-11 by



Thomas Bruun
Managing Director, ETA-Danmark

ANNEX 1
WOOD-CONCRETE COMPOSITE SLAB COMPOSED WITH
ASSY PLUS VG SCREWS

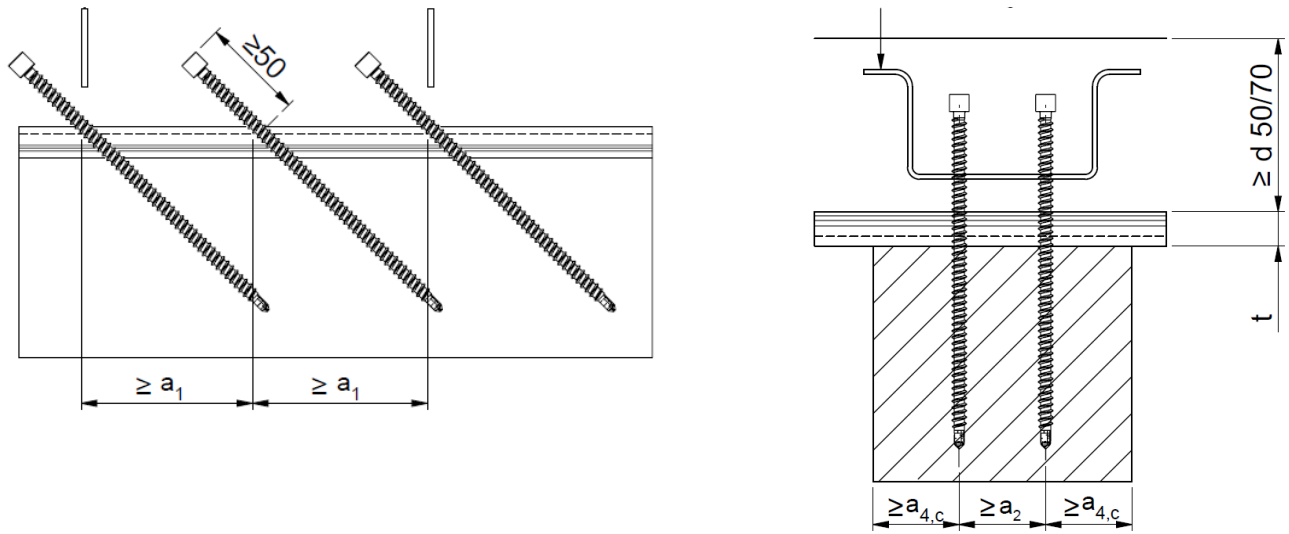

Figure 1.1a Elevation on (left) and cross-section through (right) a composite member with ASSY plus VG screws

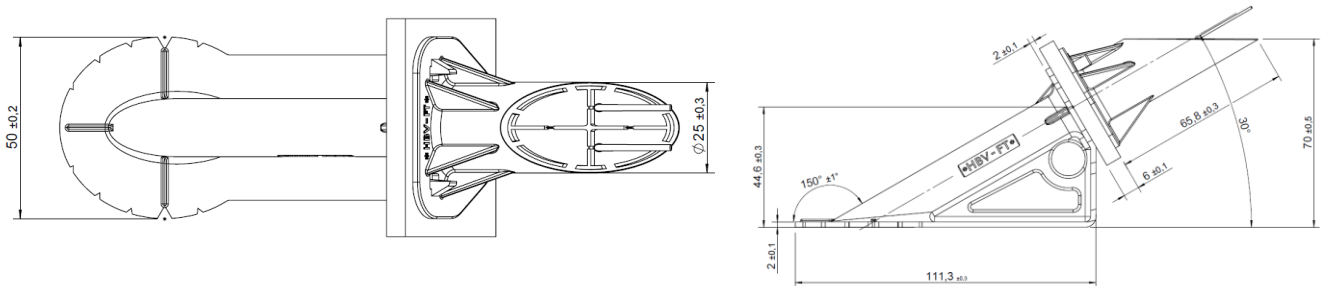

Figure 1.1b Top (left) and side (right) view of a FT-connector

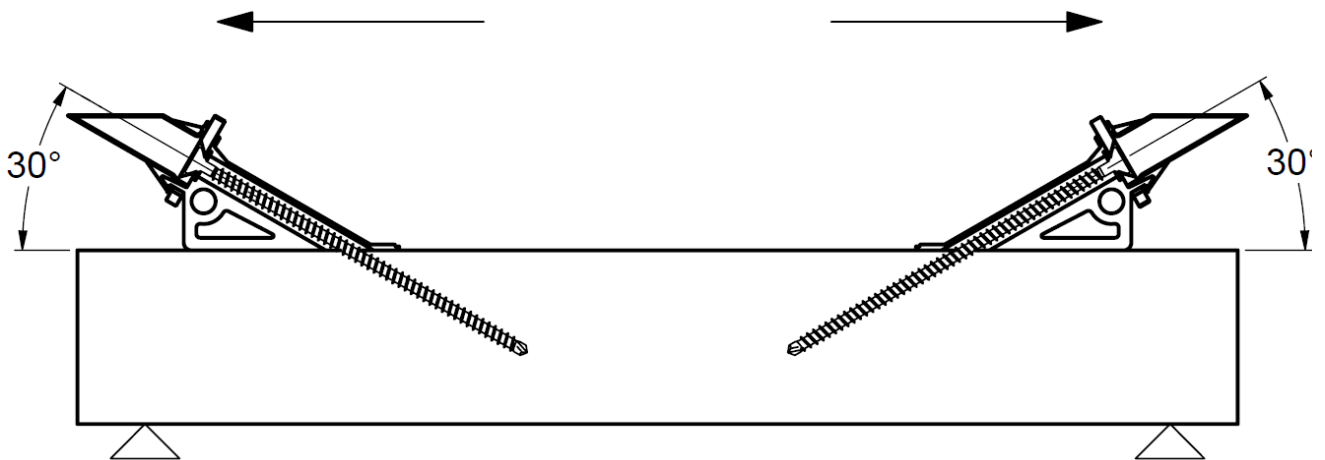

Figure 1.1c Arrangement of ASSY plus VG screws and FT-connectors

The FT connector consists of a metal part in between two plastic parts; the metal part is made from steel in accordance with EN 10027-1 and CR 10260 with the following characteristics:

Tensile strength R_m [MPa]: max. 440
 Yield strength R_{eL} [MPa]: 1 70 – 340
 Elongation min. $L_0 = 5,65 \sqrt{S_0}$ [%]: 28

The plastic part is made from PP (Polypropylene).

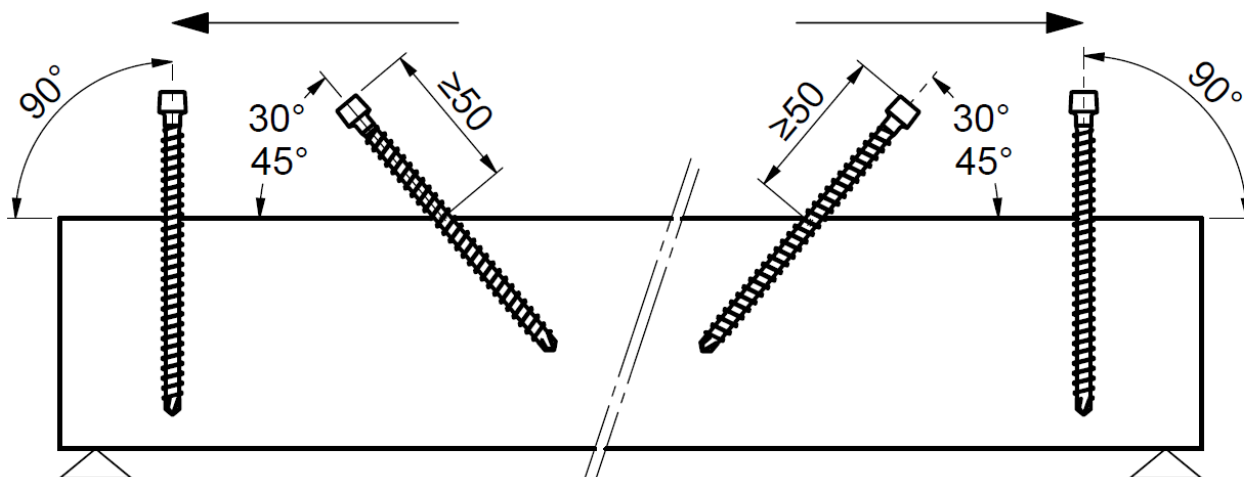

Figure 1.1d Arrangement of ASSY plus VG screws in a composite member

Table 1.1 Minimum spacing, end and edge distances for ASSY plus VG screws in mm

ASSY plus VG screw	8xl - 30° to 45°	8xl - 90°	10xl - 30° to 45°
Spacing parallel to grain a_1	80	80	120
Spacing perpendicular to grain a_2	24	24	30
Loaded end distance $a_{3,t}$	-	96	-
Unloaded end distance $a_{3,c}$	40	56	50
Edge distance $a_{4,c}$	24	24	30

Spacing a_1 in a plane parallel to grain may be reduced to $5 \cdot d / \sin \alpha$, if the condition $a_1 \cdot a_2 \cdot \sin \alpha \geq 25 \cdot d^2$ is fulfilled.

The composition of the screw materials is deposited at ETA-Danmark.

The length and diameter of the screws is given in Annex 3. More exact description of the shape and tolerances of the screws are referred to under 3.2.2.1 in the Control plan.

ANNEX 2 MECHANICAL PROPERTIES

Resistance and stiffness

Structural model

Composite members with ASSY plus VG screws are to be designed taking into account the influence of the slip occurring in the joints. A method for the calculation of the load bearing capacity and the deformation of mechanically jointed beams or columns is given in Annexes B and C of Eurocode 5 Part 1-1: General – Common rules and rules for buildings. Calculations should be carried out assuming a linear relationship between force and slip. Alternative methods for the calculation based on numerical models are also applicable.

For the determination of the internal forces and moments an elastic behaviour of the concrete may be assumed if the tensile stress in the concrete does not exceed twice the concrete tensile strength.

Friction between timber and concrete may only be taken into account, if no interlayer between timber member and concrete is present. In this case, the friction coefficient may be assumed as $\mu = 0,25$.

In order to apply the friction between the concrete slab and the timber beam for the calculation of the system, the following conditions shall be fulfilled:

- Static system as single span or continuous girder
- Predominantly static load
- Screws arranged unidirectional with systematically existing compression force between wood and concrete for reasons of equilibrium
- No interlayer

Apart from the design of the composite member, the load-carrying-capacity of the concrete layer spanning between the timber beams and the shear capacity of the timber member in the perimeter area around the screws should be checked.

The timber beam may only be arranged on top of the concrete slab, if tensile forces perpendicular to the joint line between timber and concrete are transferred by screws arranged perpendicular to the joint line.

The support of the wood concrete composite elements shall be carried out via the lower cross-sectional part either directly by contact or by appropriate connections.

Design of the wood-concrete composite slab

The design of the wood-concrete composite slab in the ultimate and the serviceability limit states shall take into account the influence of creep, concrete shrinkage and moisture changes. The verification of the limit states is to be performed both for the initial state ($t = 0$) and the final state ($t = \infty$). The influence of creep and moisture changes may be taken into account by reducing the modulus of elasticity of the timber and concrete and the slip modulus to be used in calculations analogous with EN 1995-1-1. The values of the deformation factors k_{def} given in Table 2.1 should be used. For prefabricated concrete slabs, the concrete shrinkage may be disregarded.

Table 2.1 – Values of k_{def} for timber, concrete and ASSY plus VG screws

Material	Service class	
	1	2
Solid timber, EN 14081-1	0,6	2,0
Glued Laminated timber, EN 14080	0,6	2,0
LVL, EN 14374	0,6	2,0
Cross laminated timber, ETA	0,8	2,0
Concrete, EN 206-1	2,5	2,5
ASSY plus VG screw connection	0,6	4,0

For timber-concrete composite joints made with ASSY plus VG screws the slip modulus K_{ser} per fastener under service load parallel to the shear plane should be taken from Table 2.2 with l_{ef} in mm.

Table 2.2 – Values of K_{ser} for timber-concrete-joints with ASSY plus VG screws

ASSY plus VG screw orientation	K_{ser} in N/mm			
	With interlayer		Direct contact between timber and concrete	
	d = 8 mm	d = 10 mm	d = 8 mm	d = 10 mm
90°	700	-	2000	-
45°	100 l_{ef}	-	100 l_{ef}	-
30°	-	45 ($l_{ef} - 2 \cdot t_{ib}$)	-	45 ($l_{ef} - 2 \cdot t_{ib}$)

For timber-concrete composite joints made with ASSY plus VG screws the characteristic load bearing capacity per fastener F_{Rk} parallel to the shear plane should be taken from Table 2.3 with ρ_k in kg/m³ and d and l_{ef} in mm. Characteristic yield moment M_{yk} is given in Table 2.4.

Table 2.3 – Values of F_{Rk} for timber-concrete-joints with ASSY plus VG screws.

ASSY plus VG screw orientation	F_{Rk} in N	
	With interlayer	Direct contact between timber and concrete
$\alpha = 90^\circ$	$f_{h,2,k} \cdot d \cdot t \left[\sqrt{1 + \frac{4 \cdot M_{y,k}}{f_{h,2,k} \cdot d \cdot t^2} + \frac{f_{h,1,k}}{2 \cdot f_{h,2,k}}} - 1 \right]$	$\sqrt{4 \cdot M_{y,k} \cdot f_{h,2,k} \cdot d}$
$\alpha = 30^\circ$ or $\alpha = 45^\circ$	$(\cos \alpha + \mu \cdot \sin \alpha) \cdot \min \begin{cases} F_{ax,\alpha,Rk} \\ f_{tens,k} \end{cases}$	
where:		
F_{Rk}	is the characteristic load-carrying capacity per ASSY plus VG screw in N;	
t	is the interlayer thickness in mm;	
t_{ib}	is the interlayer batten thickness in mm; the interlayer batten consists of timber or wood-based panels with a maximum width of 40 mm and a maximum thickness of 50 mm (only for prefabricated concrete members in combination with the FT-Connector and setting the screws after hardening of the concrete);	
$f_{h,1,k}$	is the characteristic embedment strength in the interlayer in MPa;	
$f_{h,2,k}$	is the characteristic embedment strength in the timber member in MPa;	
d	is the ASSY plus VG screw diameter in mm;	
$M_{y,k}$	is the characteristic fastener yield moment in Nmm;	
$F_{ax,\alpha,Rk}$	is the characteristic withdrawal capacity in N; $F_{ax,\alpha,Rk} = \frac{f_{ax,k} \cdot d \cdot l_{ef}}{1,2 \cdot \cos^2 \alpha + \sin^2 \alpha} \cdot \left(\frac{\rho_k}{350} \right)^{0,8}$	
l_{ef}	is the penetration depth of the ASSY plus VG screw in the timber member in mm; for concrete flanges loaded in tension, the value taken into account for l_{ef} shall be limited to 110 mm for 8 mm screws and to 170 mm for 10 mm screws	
ρ_k	is the characteristic timber member density in kg/m ³ ;	
μ	Friction coefficient; for direct contact between timber and concrete $\mu = 0,25$; otherwise $\mu = 0$.	

Table 2.4 – Properties of ASSY plus VG screws

ASSY plus VG screw	d = 8 mm	d = 10 mm
Yield moment $M_{y,k}$ [Nm]	20	36
Tensile capacity $f_{tens,k}$ [kN]	17	32
Withdrawal parameter $f_{ax,k}$ [N/mm ²]	11	10

Resistance to fire

Simplified rules in EN 1995-1-2 for calculation of resistance to fire in case of screws are applicable for constructions made by ASSY plus VG screws.

Thus, in design of works, fire resistance of the timber members may be determined according to EN 1995-1-2 and the fire resistance of the concrete flange according to EN 1992-1-2, if the national rules allow for calculation.

**ANNEX 3
DRAWINGS OF THE ASSY PLUS VG SCREWS**

Head types for D=8.0

Countersunk head – design: with and without raise, with and without milling pockets	Countersunk head with cutter ribs - design with and without raise	Kombi hexagonal head
Large washer head	Cylinder head	

Thread types for D=8.0

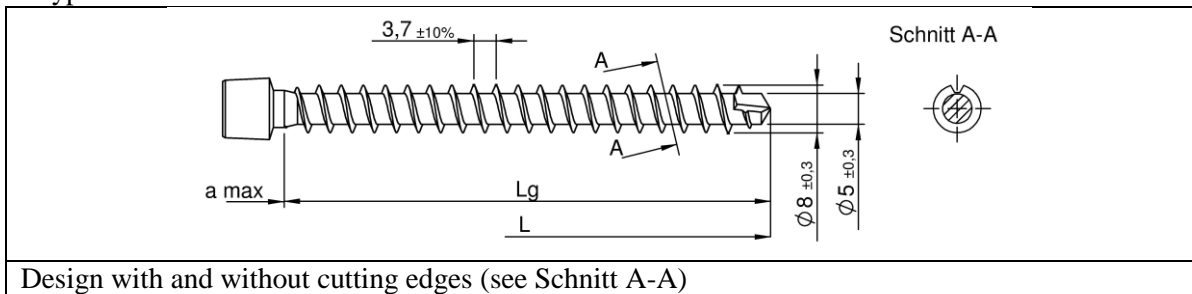

Lengths for D=8.0

Countersunk- and Cylinder head

L	Lg	a max
+1.0	+5.0	
- 5.0	- 9.0	
150	139	14.0
...	...	
280	269	14.0

Large washer- and Kombi hexagonal head

L	Lg	a max
+1.0	+7.0	
- 5.0	- 7.0	
150	139	8.0
...	...	
280	269	8.0

L	Lg	a max
+1.0	+5.0	
- 10.0	- 14.0	
290	279	15.0
...	...	
450	439	15.0

L	Lg	a max
+1.0	+7.0	
- 10.0	- 12.0	
290	279	9.0
...	...	
450	439	8.0

L	Lg	a max
+5.0	+12.0	
- 15.0	- 21.0	
460	446	20.0
...	...	
600	586	20.0

L	Lg	a max
+5.0	+14.0	
- 15.0	- 19.0	
460	446	14.0
...	...	
600	586	14.0

All dimensions in mm.

Head types for D=10.0mm

<p>Countersunk head – design: with and without raise, with and without milling pockets</p>	<p>Countersunk head – design: with and without raise, with and without milling pockets</p>	<p>Countersunk head with cutter ribs - design with and without raise</p>
<p>Kombi</p>	<p>Kombi hexagonal head</p>	

Thread types for D=10.0

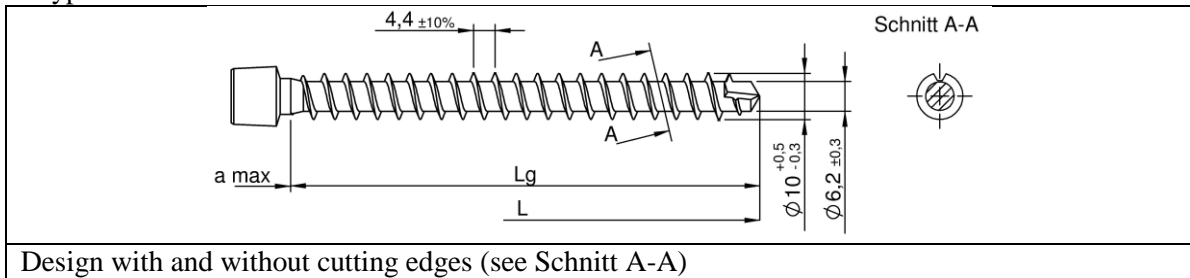

Lengths for D=10.0

Countersunk head

L	Lg	a max
+1.0	+5.0	
- 5.0	- 11.0	
200	188	18.0
...	...	
280	268	18.0

L	Lg	a max
+1.0	+5.0	
- 10.0	- 16.0	
290	278	18.0
...	...	
450	438	18.0

L	Lg	a max
+5.0	+12.0	
- 15.0	- 24.0	
460	445	23.0
...	...	
800	785	23.0